

BASIC ELECTRICITY

STUDY COURSE for Home Appliances

HOW TO READ:

- *VOLT-OHM-MILLIAMMETER
TEST INSTRUMENTS*

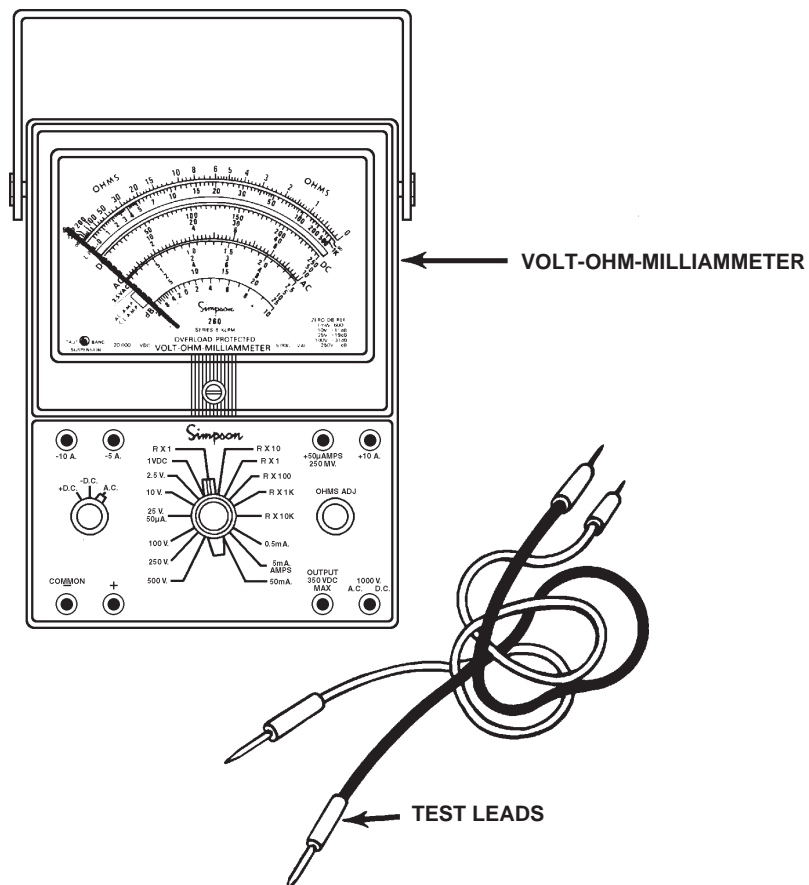

WHIRLPOOL CORPORATION does not assume any responsibility or any liability in connection with the use of this manual.

© 1989, 1993, 2000 WHIRLPOOL CORPORATION

All rights reserved. No portion of this book may be reproduced in any form without written permission from WHIRLPOOL CORPORATION.

® The trademarks WHIRLPOOL ,  Whirlpool ,  Whirlpool , and *FSP* are registered trademarks of Whirlpool Corporation.

INTRODUCTION

The material presented in this module is intended to provide you with an understanding of the fundamentals of electricity as applied to major appliances.

Major appliances have become more sophisticated, taking them out of the screwdriver and pliers category. Their electrical circuits include several different types of automatic controls, switches, heaters, valves, etc.. Semiconductors, solid-state controls, and other components usually associated with radio and television electronic circuits, are being engineered into automatic washers, dryers, dishwashers, and refrigerators.

The appliance technician is emerging into a professional status of his own. He must prepare himself now to be able to perform his duties today as well as to retain his professionalism in the future.

No longer is on-the-job training sufficient to prepare technicians for the complicated procedures required for today's sophisticated appliances. This training can best be obtained through organized classroom study and application. However, much of the knowledge necessary to service today's appliances can be obtained through study courses. Completion of this and other courses will provide you with sufficient understanding of appliances and their operation to enable you to do minor service. It will also serve as a valuable stepping stone to more advanced study and on-the-job training to improve your servicing skills.

Information contained in this module is used on WHIRLPOOL® appliances.

TABLE of CONTENTS

	PAGE
CHAPTER 1	3
How to Read the Volt-Ohm-Milliammeter Test Instrument	

***TESTSee Test Book LIT787743**

****NOTE: We recommend taking the TEST for MODULE 4, right after studying it.***

CHAPTER 1

HOW TO READ THE VOLT-OHM-MILLIAMMETER TEST INSTRUMENT

WHAT'S A VOM?

VOM is short for volt-ohm-milliammeter. (VOM's are sometimes called multimeters, because they do more than one thing.)

A typical VOM will allow you to measure voltage, resistance, and current.

Voltage = electrical pressure.

Resistance = the amount of resistance holding back the flow of current (measured in ohms).

Current = the amount of electricity flowing through a wire or circuit component (measured in amperes).

There are many different types and brands of VOM's. Some of them are shown below. Now you can even buy a VOM that will "speak" the reading aloud. This is handy when you can't look at the meter while you are holding the test leads to the part you are testing.

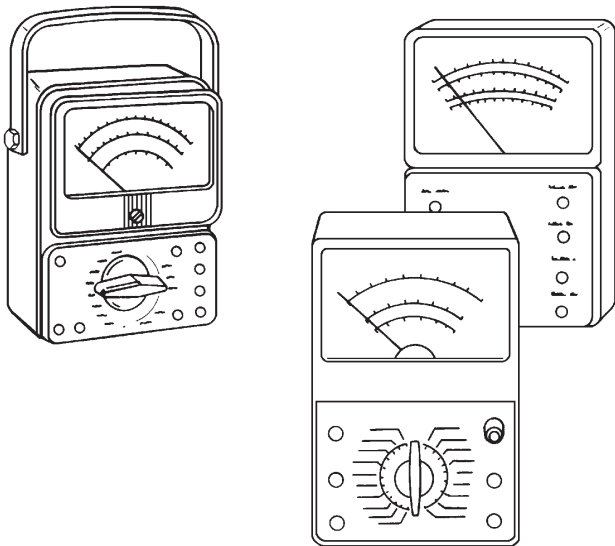

Though they look different, all VOM's do pretty much the same things.

Most VOM's will have these things:

1. **Test leads** — These are the wires coming from the meter to the part being tested.
2. **Meter scales and pointer** — (A digital display on a digital meter) These show the amount of whatever you are measuring.
3. **Function switch** — This allows you to select whether you will be measuring A.C. or D.C. volts, current, or resistance (ohms).
4. **Range selector switch** — Allows you to select the range of values to be measured.

On many meters the function switch and the range switch are one and the same; you can select functions and ranges with the one switch (as in the meter pictured below).

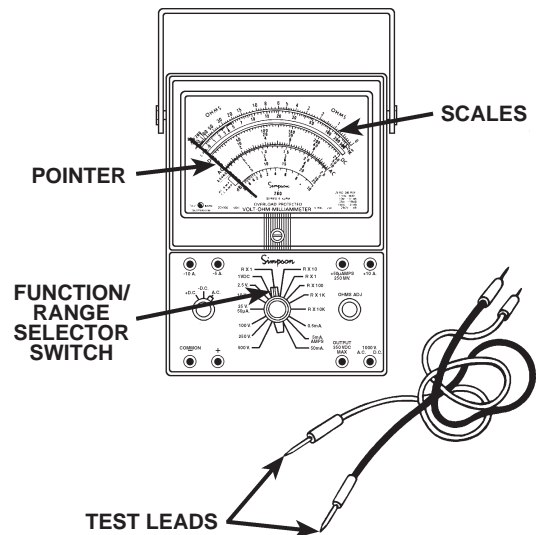

There are other minor differences between VOM's: On some the test leads are permanently attached; on others you can remove them. On some VOM's there is a reset button, on others there may be a fuse, and on still others there will be neither of these. Pushing the reset button, or replacing the fuse, lets you restart the meter if you accidentally overload it.

In spite of the differences, all VOM's are used in the same way to measure voltage, current, or resistance.

MEASURING VOLTAGE

Voltage is electrical pressure. If you don't have the right air pressure in your tires, you car won't ride right. If you don't have the right electrical pressure in an appliance, the appliance won't work right. (Most Whirlpool appliances want 115-125 volts AC in order to work right.) You can find out whether the appliance is getting the right voltage by measuring the voltage at the wall outlet (receptacle).

If an appliance isn't getting the proper voltage, nothing else you do to fix it will help.

MAKING THE MEASUREMENT

When measuring voltage, these are the steps you will follow:

1. Attach the probes (another term for **test leads**) to the meter. Plug the black probe into the outlet marked negative. Plug the red probe into the positive outlet.
2. Set the function switch to AC VOLTS.
3. Select a range that will include the voltage you are measuring. (Higher than 125 volts AC if you are measuring 120 volts; higher than 230 if you are measuring 220 volts.) If you don't know what voltage to expect, use the highest range and then switch to a lower range if the voltage is within that lower range.
4. Touch the tips of the probes to the terminals of the part to be measured.
5. Read the scale.
6. Decide what the reading means.

Making voltage measurements is easy once you know how to select and read the scales on your meter. So let's begin there.

SELECTING THE SCALES

There are several scales on your meter. To measure voltage in appliances you will use the ones marked AC/DC. (The same scales are used for both AC and DC readings.) The one you use will depend on the range and function you've set.

The numbers on the right side of the AC-DC scales tell you what ranges are available to you.

Example: This meter face has three scales for measuring voltage. One is marked 10, another 50, and the third is marked 250.

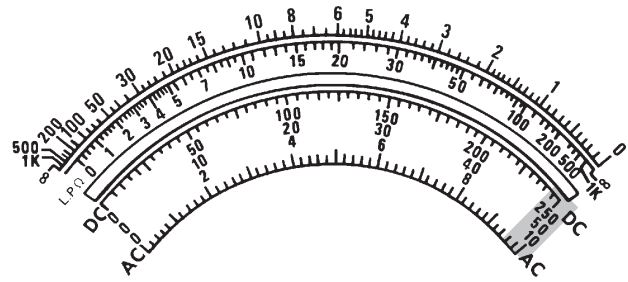

The scale you read is always determined by the position of the range switch.

If the range switch is set on 10V, you read the 0-10 scale.

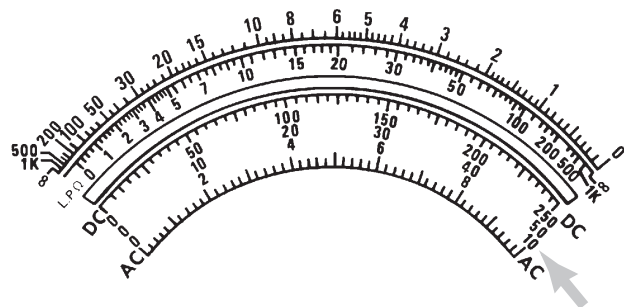
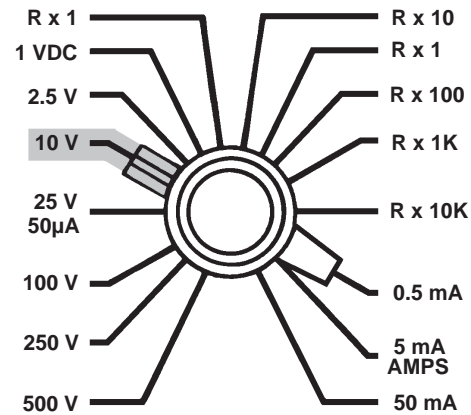

If the range switch is set on 250V, you read the 0-250 scale.

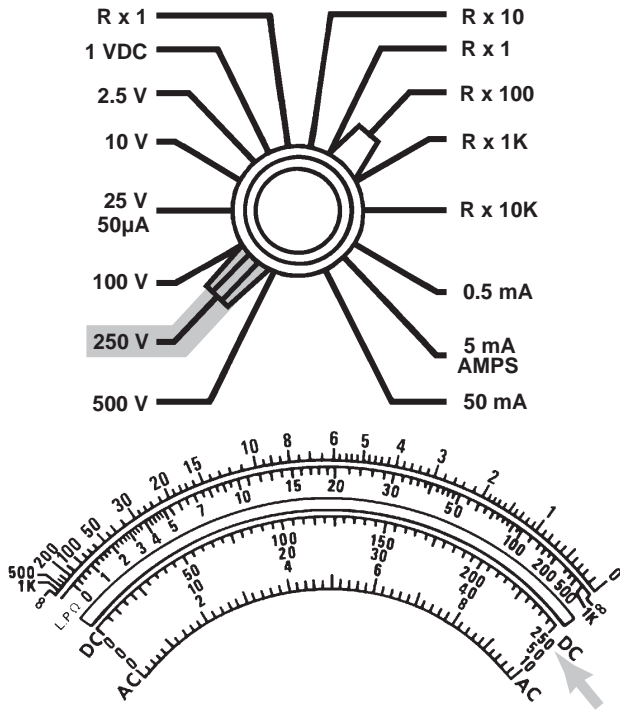

Question: If the range on this meter is set on 25V, which scale should you read?

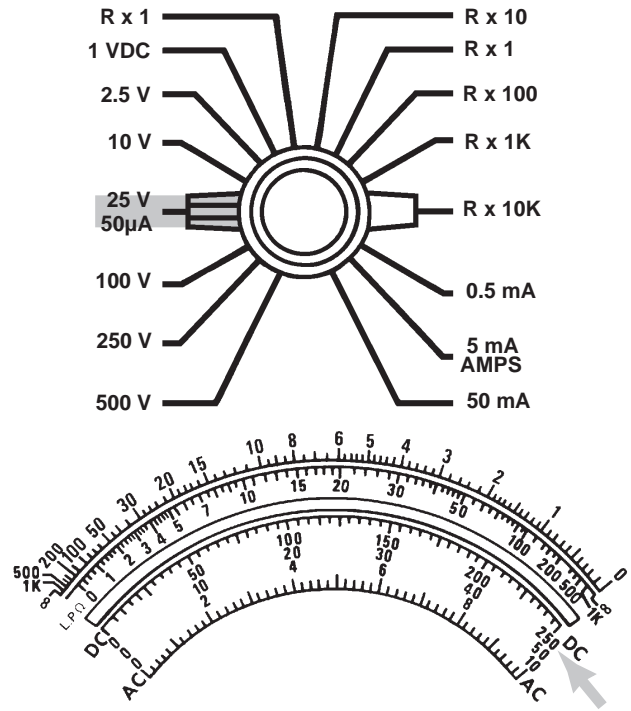

Notice that the range switch on this meter is set on 500V.

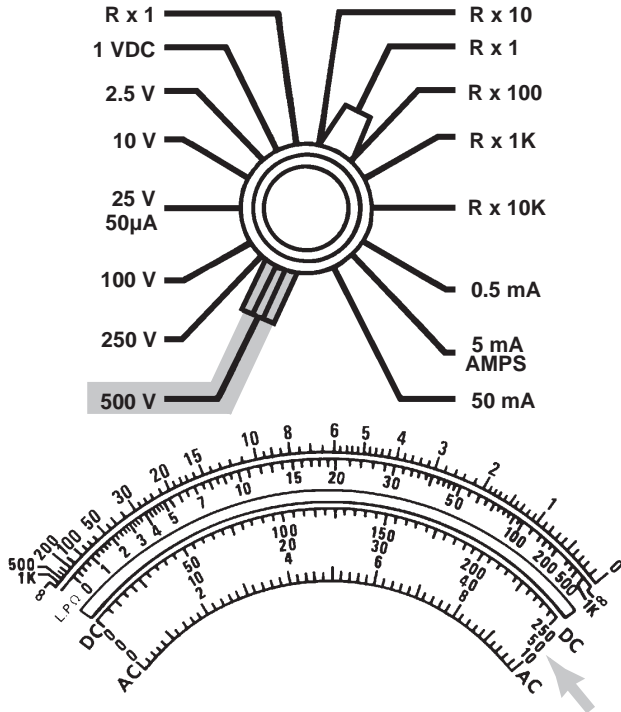

Answer: Since there is no scale that actually says 25, you would read the scale that says 250, and then divide your reading by ten (drop the last zero from your reading).

Question: Which scale should you read?

Answer: Since there is no scale that actually says 500, you would read the scale that says 50, and then multiply your reading by ten (add a zero to your reading).

LET'S PRACTICE

Look at the setting of the range switch on the examples 1 through 4, and then list to the side which scale you would read for each range shown.

1. _____ Volt scale.

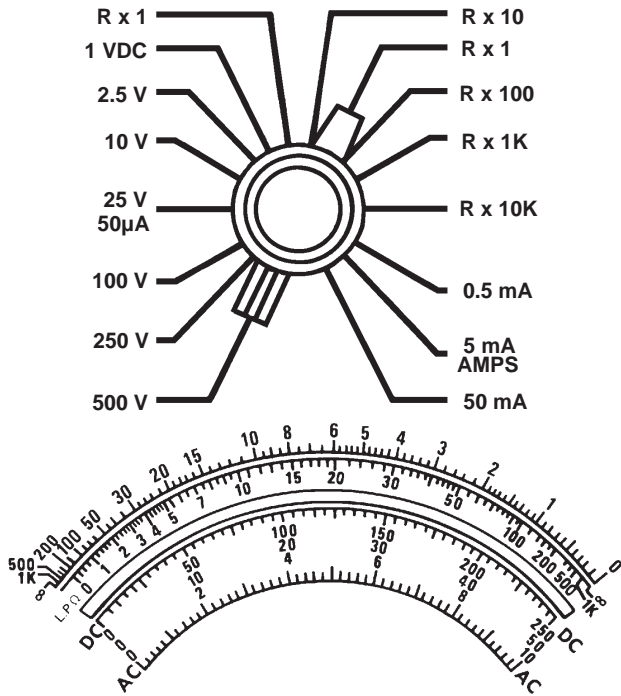

3. _____ Volt scale.

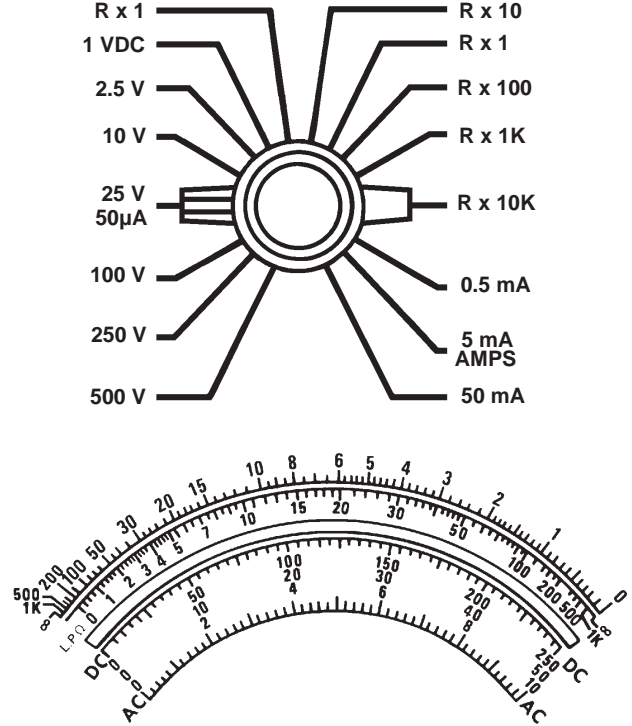

2. _____ Volt scale.

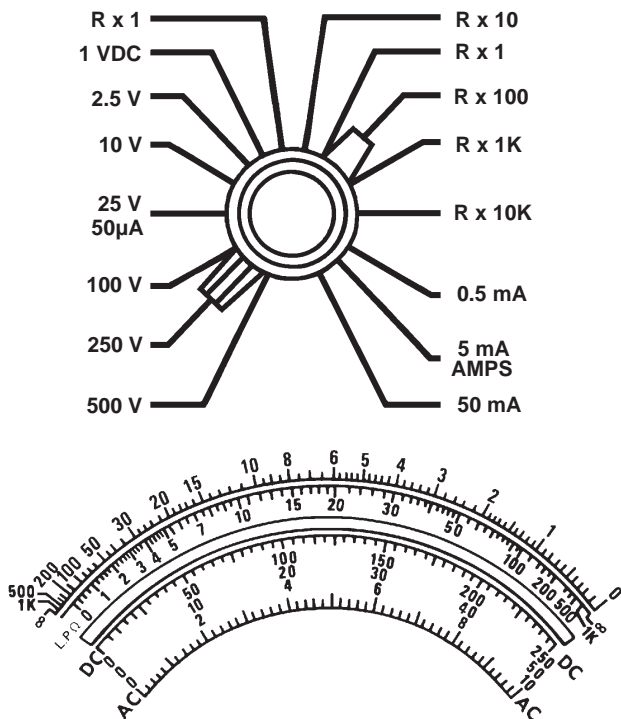

4. _____ Volt scale.

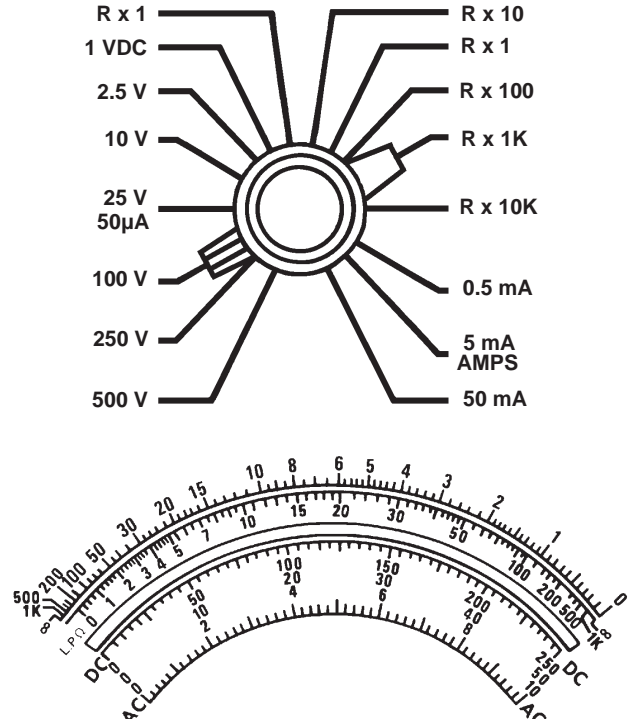

ANSWERS ON PAGE 8

READING THE AC VOLTAGE SCALE

When you read the pointer position be sure to read the line marked AC.

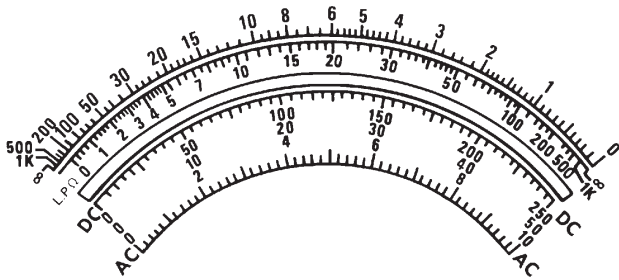

The spaces on voltage scales are always equally divided. The value of each space depends on which range you are using.

Example: When the range is set to 10V on this meter, the value of each space on the 0-10 scale is .2 (two-tenths) of a volt.

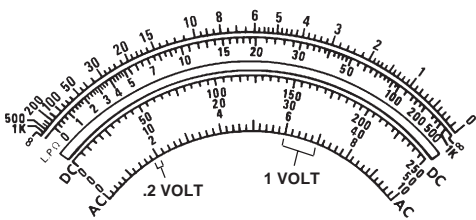
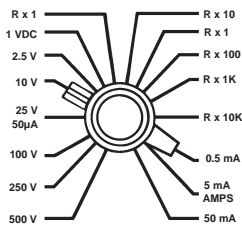

Example: When the range is set to 100V on this meter, the value of each space is 2 volts.

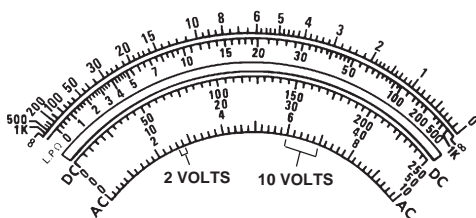
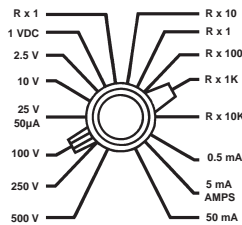

Example: When the range switch is set to 1000V on this meter, the value of each space is 20 volts.

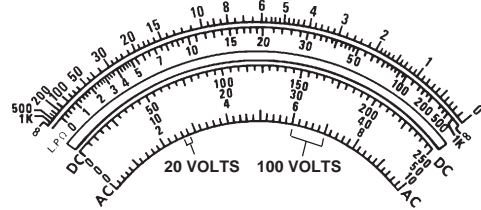
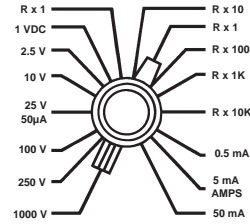

NOTE: When the pointer stops between marks, just read the value of the nearest mark.

Example: The pointer on this meter face is between 115 and 120 volts on the 250 volt scale. Read it as 120 volts. You won't gain anything by trying to read the voltage exactly.

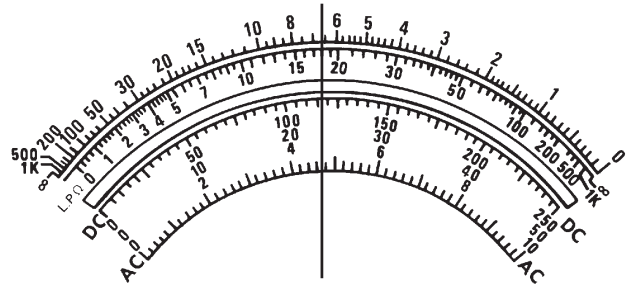

Example: The pointer on this meter is between 35 and 36 volts on the 50 volt scale. Read it as 36 volts. The difference between 35.5 and 36 isn't worth bothering about.

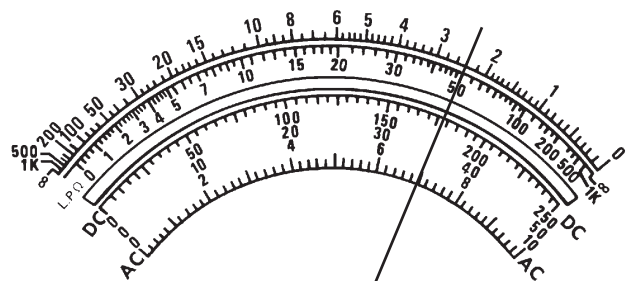

SELF-CHECK

ANSWERS FROM PAGE 6

1.

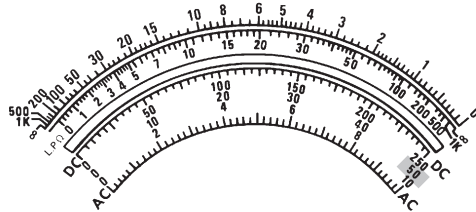
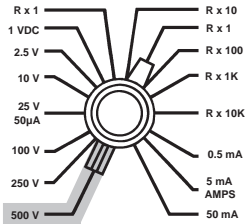

Read the 50-volt scale — add a final zero for the reading.

2.

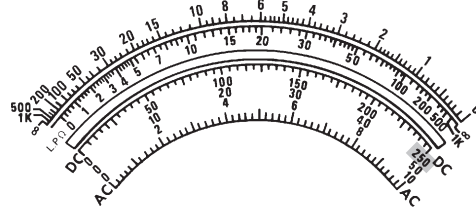
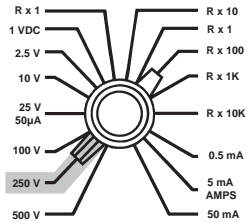

Read the 250-volt scale.

3.

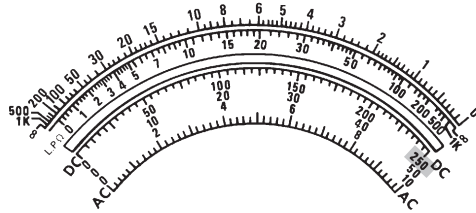
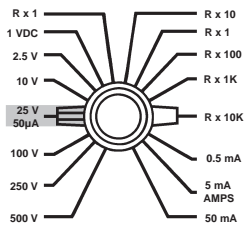

Read the 250-volt scale — drop the last zero for the reading.

4.

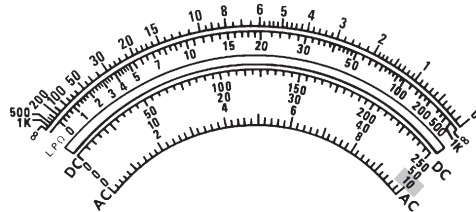
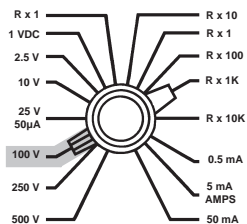

Read the 10-volt scale — add a final zero for the reading.

LET'S PRACTICE AGAIN

Look at the meters below. Write the reading in the space provided. NOTE: Be sure to look at the range switch first so that you will read the correct scale.

1. _____ Volts.

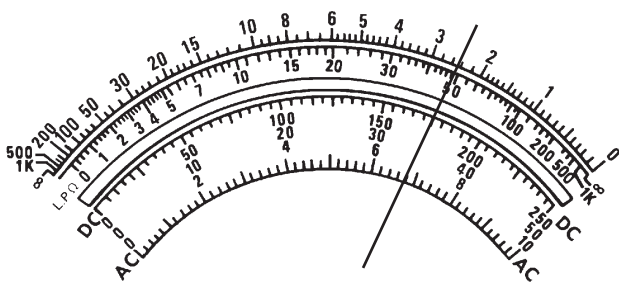
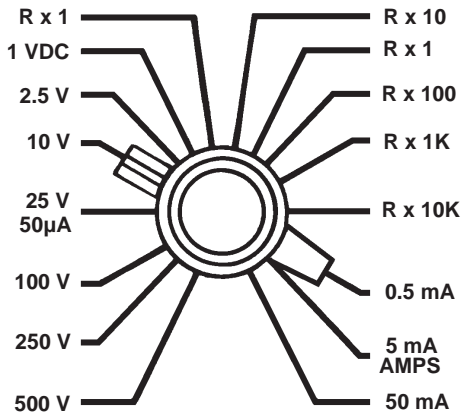

3. _____ Volts.

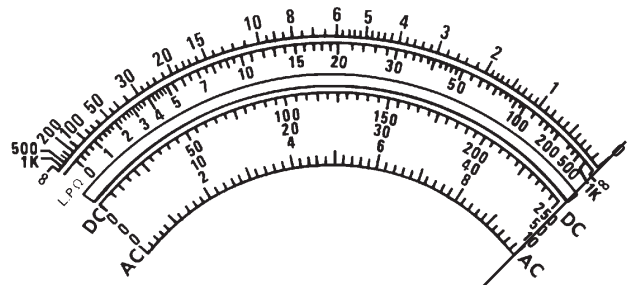
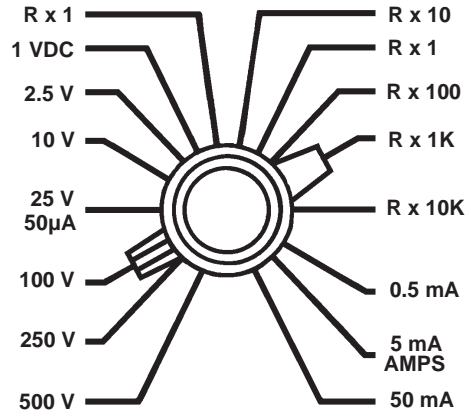

2. _____ Volts.

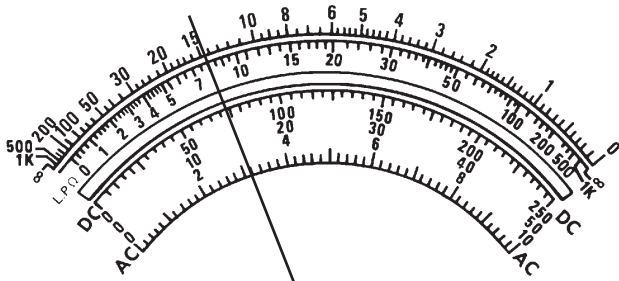
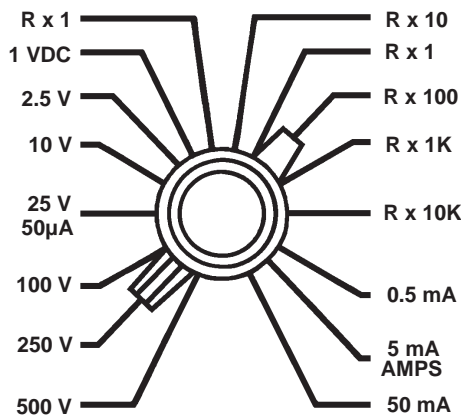

4. _____ Volts.

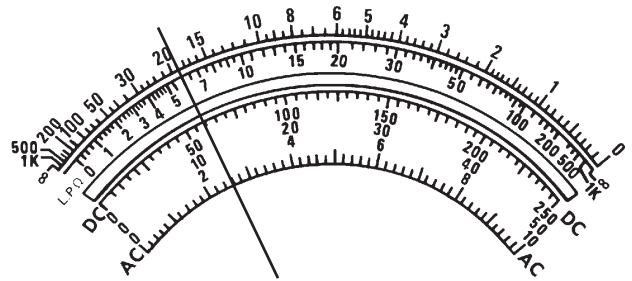
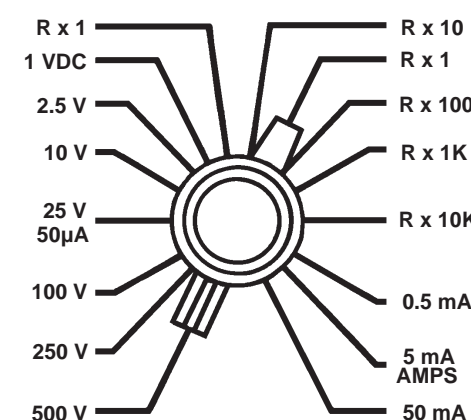

ANSWERS ON PAGE 10

SELF-CHECK

ANSWERS FROM PAGE 9

1.

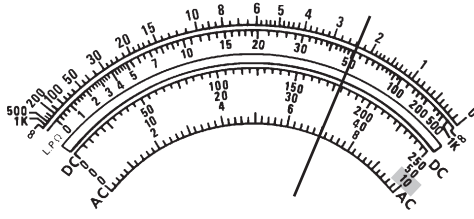
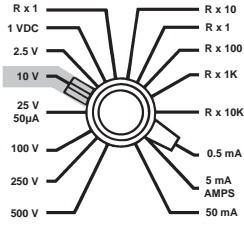

7 Volts.

2.

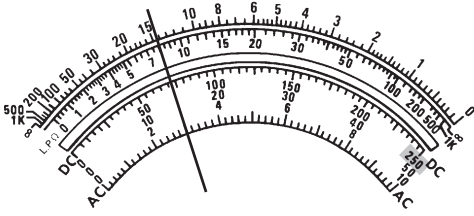
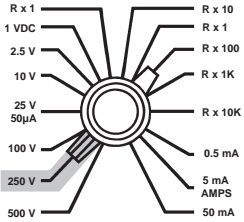

75 Volts.

3.

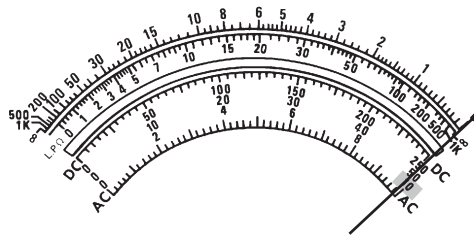
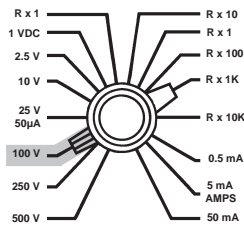

100 Volts.

4.

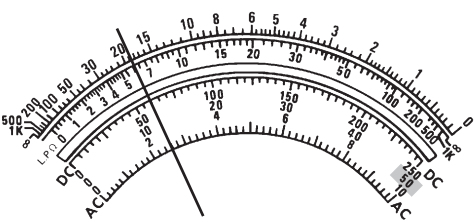
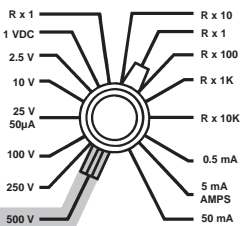

120 Volts.

MEASURING LINE VOLTAGE

Now that you know how to select the scales and read the meter, you're ready to learn how to make measurements with it. First, how to measure line voltage. This is the first and most important part of checking out an appliance that does not operate.

Line voltage is the voltage coming from the wall outlet.

There should be approximately 120 volts AC at the outlet under *no load* conditions.

No load means that no appliance is connected, or that an appliance is connected but is turned off.

To measure line voltage-no load:

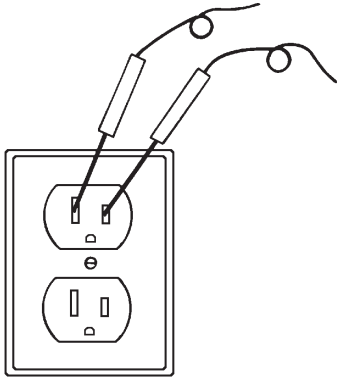

1. Set meter to measure AC volts.
2. Set range selector to range nearest to, but higher than, 120 volts.
3. Insert either test lead into one slot of an empty wall receptacle.
4. Insert the other test lead into the other slot of the same outlet. (Disregard the center hole for this test).
5. Read the meter. The reading should be between 115 and 120.

NOTE: Most appliances are rated 120V, but will work on voltages ranging from 110 to 125.

To measure line voltage-under load:

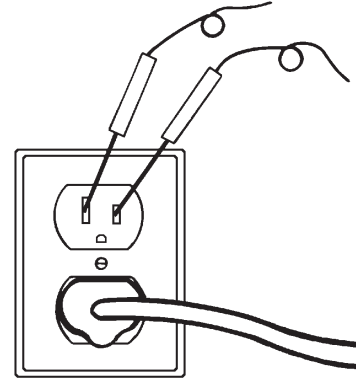

1. Make sure that (a) an appliance is plugged in to one of the receptacles and that (b) the appliance is turned on.
2. Follow steps 1 through 5 for no load conditions, inserting your test leads into the empty receptacle next to the one into which the appliance is plugged.
3. Under load conditions (appliance is turned on), your reading will be slightly less than under no-load conditions.

Note: Appliances with heavy drive motors, such as automatic washers and dishwashers, should also be tested at the moment of start. If the voltage drops more than 10% of voltage when the motor is started, it means that there is a problem with the electrical supply (the electricity coming into the receptacle).

TESTING FOR GROUND AND POLARITY

Ground

A ground is a voltage reference point.

If a component is grounded (connected) to a chassis (the metal frame on which components are mounted), it means that there is no voltage between the component and the chassis.

If a chassis is grounded to the earth, it means that there is no voltage between the chassis and the earth.

If there is voltage between a chassis and the earth, think of it as voltage on the loose. It's dangerous. If you stand on the earth and touch the chassis, the voltage will cause electricity to flow through your body. Or through the customer's body. Bad news either way! So it is important to make sure that the outlets into which your appliances are plugged have been correctly wired. That will protect the users from electrical shock.

You do that by checking for ground and polarity.

Polarity

If an outlet is wired *backwards*, that is, if the *hot wire* is connected to the long slot of the outlet, the appliances connected to that outlet may be unsafe to operate or blow the fuse or trip the circuit breaker.

To test for ground:

1. First, test for line voltage. (If there is no voltage you can't test for ground.)
2. Notice that the receptacle has a longer and a shorter slot. If the outlet has been mounted right side up, the longer slot will be on the left.

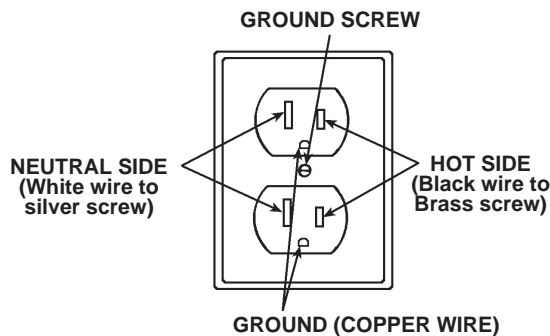

3. Test for voltage between the short slot and the ground receptacle (the round hole). If there is line voltage between these two points it means that the receptacle is grounded.

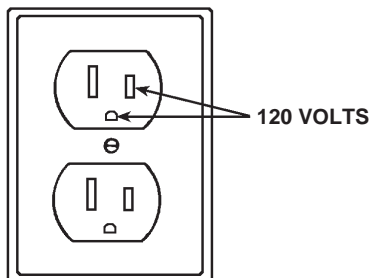

4. If there is no round hole (ground receptacle), touch one of your probes to the screw that fastens the coverplate to the outlet.

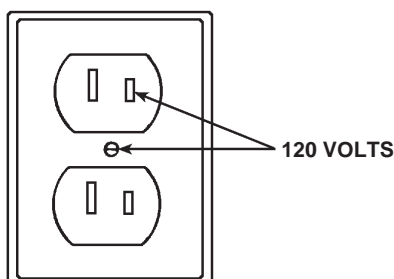

To test for polarity:

1. Test to make sure that there is line voltage between the longer and shorter slots.

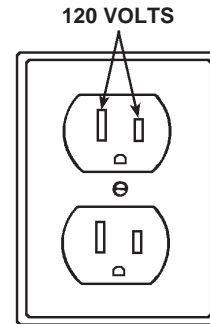

2. Test to make sure there is line voltage between the short slot and the center screw or the round hole (ground receptacle).

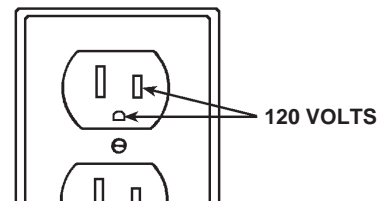
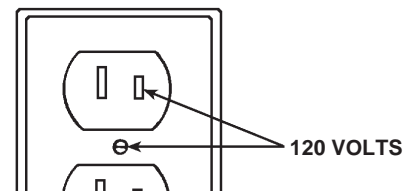

3. Test to make sure there is **NO VOLTAGE** between the longer slot and the center screw or the round hole (ground receptacle).

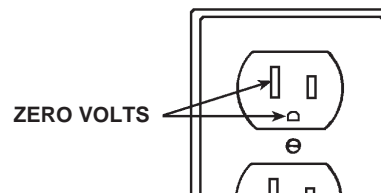
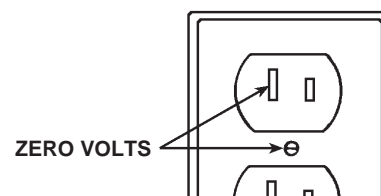

If these three tests don't work out this way, the outlet is incorrectly wired and should be corrected by a licensed electrician.

MEASURING RESISTANCE (OHMS)

Electrical appliances will not work unless there is a complete path around which electricity can flow. As you know, a complete path is called a circuit.

If there is a break in the circuit, the appliance won't work.

Sometimes we deliberately break the circuit. For example, when we turn a switch to its OFF position, we interrupt the flow of electricity. (It's just like breaking a wire in two, except more elegant.)

When there is a complete path we say we have *continuity* in the circuit. When we test to find out whether there is a break in the path, we say we are making a continuity check.

How? Continuity checks are made by measuring the amount of resistance there is to the flow of electricity. If there is so much resistance that it is too high to measure (called *infinite*), then we say that the circuit is OPEN (there is no complete path for the electricity to follow).

Infinite resistance = open circuit

If there is no measurable resistance to the flow of electricity, we say we have an open circuit or infinite resistance between the two points being measured.

Some measurable or zero resistance = continuity

If there is SOME resistance, it means that there is continuity, but that there is also one or more loads on the line — a light, a motor, etc.

NOTE: A load is an electrical component that uses electricity to work: e.g., a light bulb, a motor, a heater coil.

If there is NO resistance between the two points, it means the electricity is flowing directly from one point to the other.

Example: In the circuit below, the current would flow directly from point C to point D, without flowing through load X.

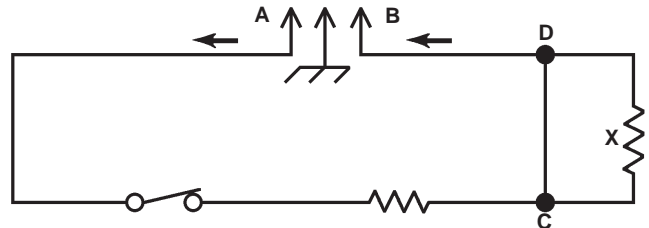

If we wanted current to flow from point C to D, we would say we had continuity. But if we DIDN'T want it to flow from point C to D, that is, if it flowed from C to D by accident or error, then we say we have a short circuit, or short.

Unwanted continuity = short circuit

Example: In the circuit below, point X is connected to earth ground. This is the same as connecting it to point B, and so current would flow through loads R and S, and then directly to ground.

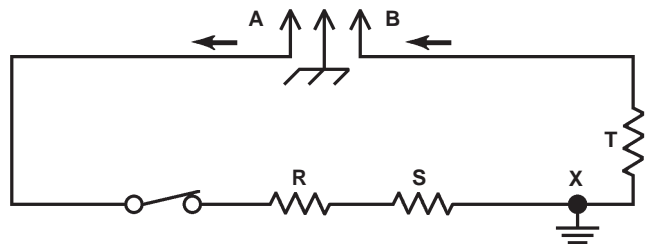

When this happens by accident, we say the circuit is *shorted to ground*, or we might just say the circuit is shorted.

SETTING UP THE METER

Measuring ohms (the unit of measure for resistance) is like measuring voltage, except that the measurements are always made with the power turned OFF. Why? Because when you're measuring ohms, you've set your meter to measure the continuity of a circuit, NOT the quantity of current. If you jolt your meter with a shot of electrical power when it's set for ohms, you'll destroy it.

Let's look at the steps one at a time.

1. *Attach the leads to the meter.*
Plug the black lead into the negative outlet, the red lead into the positive outlet.

2. *Set the function switch on OHMS.*

3. *Set the range.*
The range selector switch will always have several ranges, of resistance (ohms) measurements. The ranges are shown like this:

Rx1: The actual resistance reading shown on the meter face, times 1

Rx10: The resistance reading, times ten; add one zero to the reading

Rx100: The resistance reading, times 100; add two zeros to the reading

Rx1K: The resistance reading, times 1000; add three zeros to the reading (K means 1000).

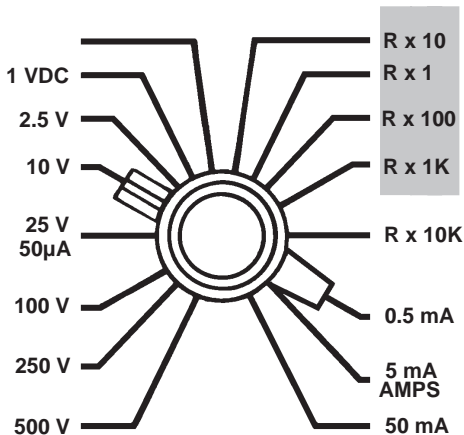

Set the range so it is higher than the resistance you expect. If you don't know what measurement to expect, use the highest setting and adjust downward to a reading of less than 50. The left side of the scale is too crowded for an accurate reading.

4. *Zero the meter.*

There is a small battery inside the meter that is used to supply power to the meter only when the OHMS function is used. Because the battery voltage changes slightly with each use, you should *zero the meter* each time you set the meter or use a different scale to measure ohms.

To *zero the meter* means to adjust the pointer so that it reads ZERO ohms when the two test leads are touched together.

Here's how to *zero the meter*.

1. Touch the tips of the leads together. (Don't hold them with your fingers).
2. Use the Ohms adjust knob on the front of the VOM to line up the pointer over the zero on the OHMS scale.

NOTE: If the meter will not *zero* it means that the battery in the VOM is weak and should be replaced.

5. *Testing.*

Touch each probe to the part or the portion of the circuit you are measuring.

Example: If you are measuring the continuity of a load such as a light bulb (or any other load you could easily remove), touch one test lead to the metal screw, and another to the bottom of the bulb (or load). If your meter shows infinite resistance it means that the filament in the light bulb is broken, and you have an OPEN (a break) circuit.

Example: If you are measuring continuity in a load that cannot be easily removed, (1) disconnect one wire from the load, and then (2) touch your test leads to the terminals where the line voltage wires are attached to the load.

6. Read the OHMS scale.

Scale direction. You'll notice that the OHMS scale is a little screwy.

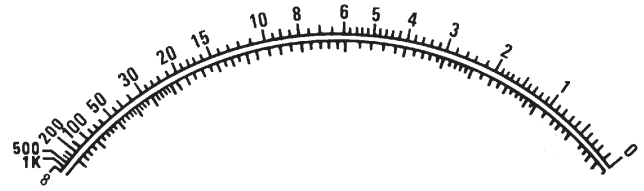
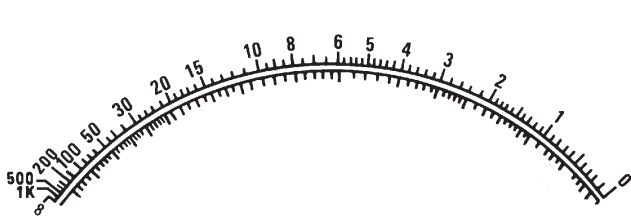

All the other scales have their highest numbers to the right, but the OHMS scale almost always has the ZERO on the right and infinite resistance to the left. Seems backwards, doesn't it?

Try thinking of it like this. When resistance is zero, more current can flow through the circuit than when resistance is higher than zero. The higher the resistance, the less electricity that can flow. In other words, an ohmmeter actually senses the amount of current flow.

So, just as the highest voltages are shown at the right of the scale, the highest possible current flow (zero resistance) is also shown at the right.

Whether it makes sense or not, that's the way it is. The OHMS scale is read opposite to the way you read the AC-DC scales.

Uneven divisions. There's another difference.

As you know, the marks on AC-DC scales are equally spaced. But as you move from right to left on the ohms scale the size of the spaces gets smaller and the numbers get bigger (the scale is compressed).



The highest reading you get is called infinite resistance.

This means that resistance is so high that current cannot flow (in other words, there is an open circuit).

When the pointer is at the high (left) end you'll have to estimate (guess) at the reading. This is no problem, because the differences in resistance at the high ends don't matter much.

Example: If a reading shows high resistance when there is supposed to be ZERO resistance, it doesn't matter if that high resistance is 5 thousand ohms or 5 million ohms. Either way, it means you have a problem.

NOW LET'S PRACTICE AGAIN

Look at the meters below. Write the reading in the space provided. NOTE: Be sure to look at the range setting before you read the scale, and remember to add zeros to your reading.

1. Reading: _____

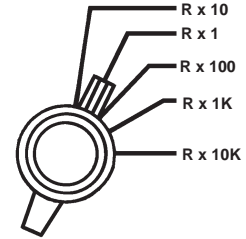
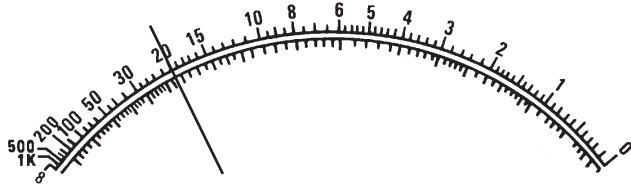

2. Reading: _____

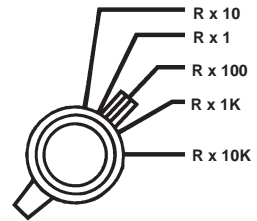
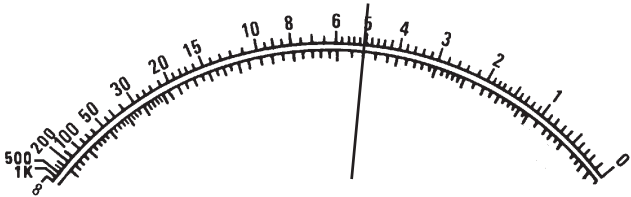

3. Reading: _____

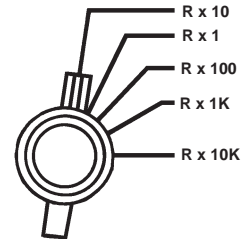
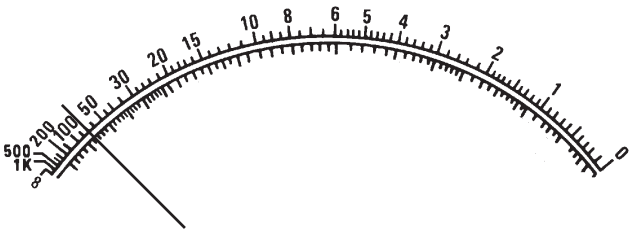

4. Reading: _____

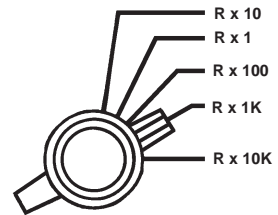
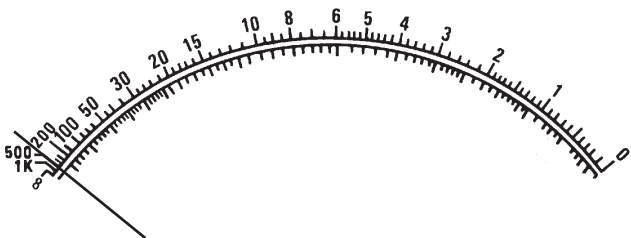

ANSWERS ON PAGE 19

5. Reading: _____

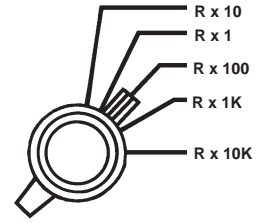
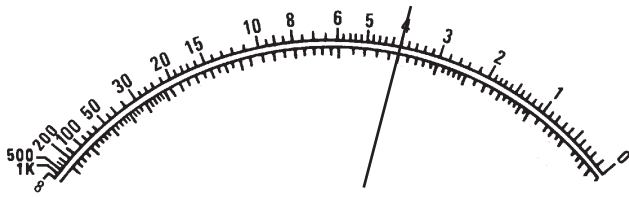

6. Reading: _____

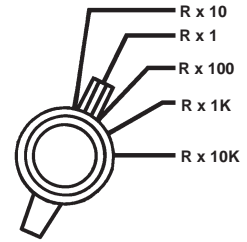
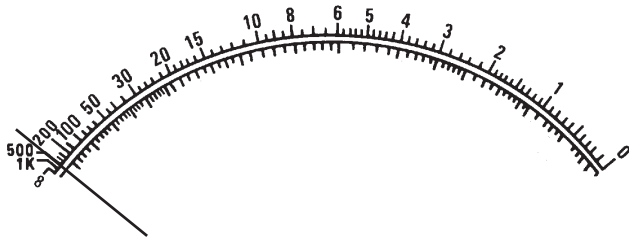

7 Reading: _____

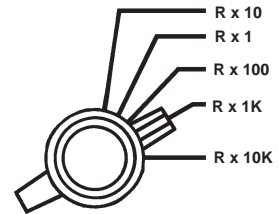
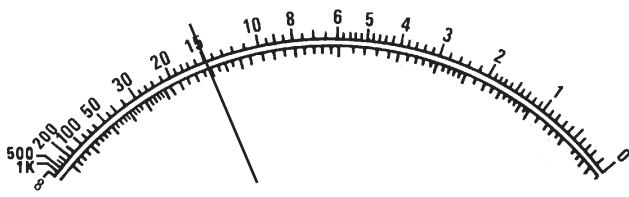

8. Reading: _____

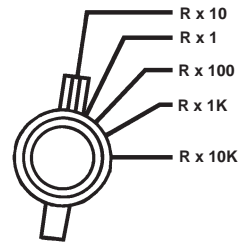
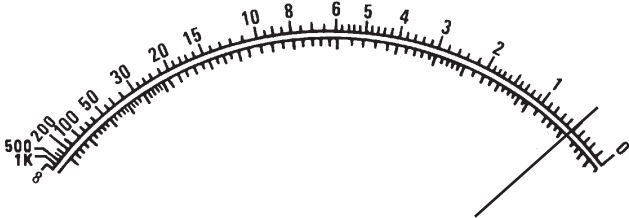

ANSWERS ON PAGE 20

SELF-CHECK

ANSWERS FROM PAGE 16

1.

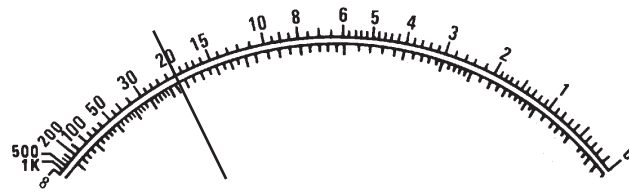
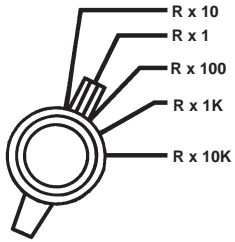

20 Ohms.

2.

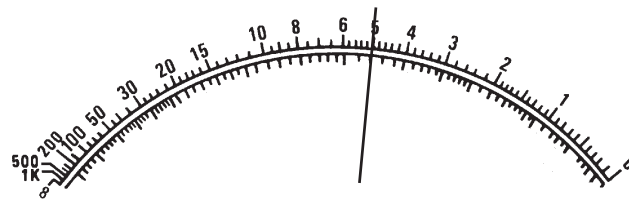
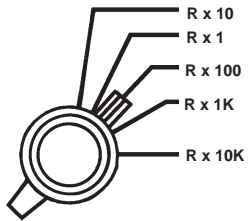

500 Ohms.

3.

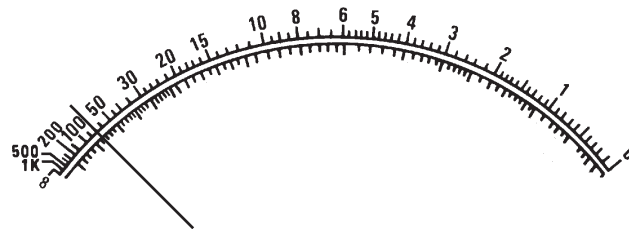
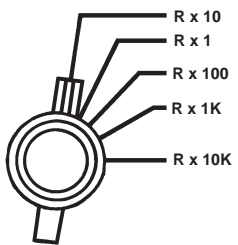

700 Ohms.

4.

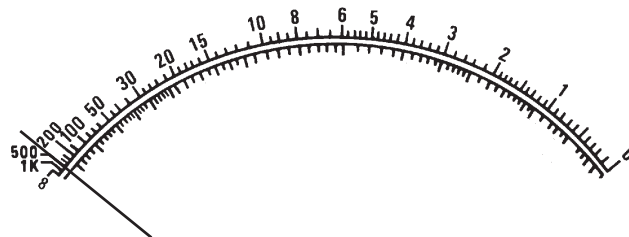
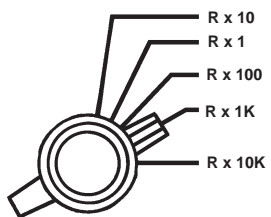

Infinite
resistance

SELF-CHECK

ANSWERS FROM PAGE 17

5.

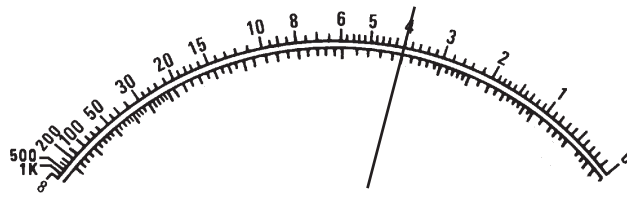
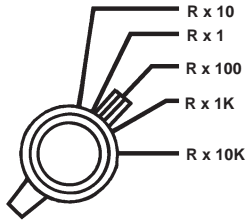

400 Ohms.

6.

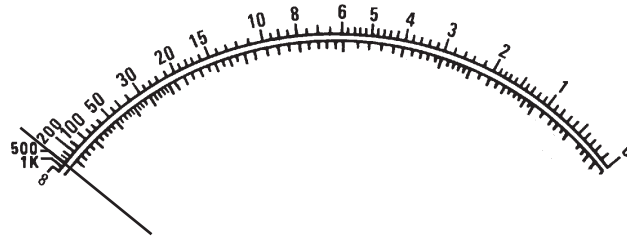
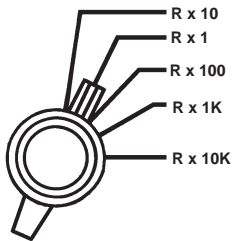

1000 Ohms.

7.

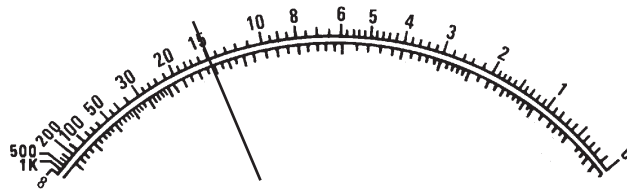
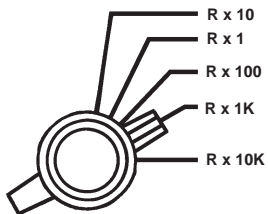

15000 Ohms.

8.

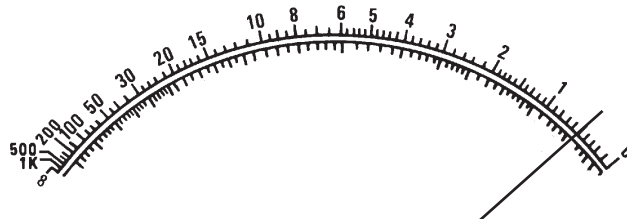
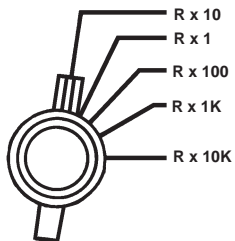

5 Ohms.

LET'S REVIEW WHAT THE TERMS AND MEASUREMENTS MEAN

INFINITE resistance means open circuit.

ZERO resistance means continuity or a possible short.

INFINITE RESISTANCE means a break in the circuit or you have picked the wrong scale.

CURRENT is like a car traveling on highways or roads. If the road has a bridge opened or washed out the car cannot get through.

It's the same with *CIRCUITS*. If there is a break (infinite resistance), the current will not flow (open circuit).

OPEN CIRCUITS are usually caused by wires that have come loose from a terminal, by broken wires, or by a connection that has been incorrectly soldered.

ZERO RESISTANCE means there is continuity or a possible short.

ELECTRICITY will follow the path of least resistance. When there is a path of *ZERO* resistance all the electricity (current) will flow through that path, instead of through the loads that make the appliances work.

A READING OF ZERO OHMS across a component means that the electricity doesn't have to do any work while flowing through the component. It's as though the current has a wide empty highway to flow through.

SHORTS are usually caused by a component that is accidentally grounded, or by wires that are touching other wires or ground.

BLANK

BLANK